



FX3U-2HSY-ADP

INSTALLATION MANUAL



Manual Number	JY997D16401
Revision	C
Date	September 2010

This manual describes the part names, dimensions, mounting, and specifications of the product. Before use, read this manual and manuals of relevant products fully to acquire proficiency in handling and operating the product. Make sure to learn all the product information, safety information, and precautions.

And, store this manual in a safe place so that you can take it out and read it whenever necessary. Always forward it to the end user.

Registration
The company name and the product name to be described in this manual are the registered trademarks or trademarks of each company.

Effective September 2010
Specifications are subject to change without notice.
© 2005 Mitsubishi Electric Corporation

Safety Precaution (Read these precautions before use.)

This manual classifies the safety precautions into two categories:

⚠ DANGER and ⚠ CAUTION.

⚠ DANGER	Indicates that incorrect handling may cause hazardous conditions, resulting in death or severe injury.
⚠ CAUTION	Indicates that incorrect handling may cause hazardous conditions, resulting in medium or slight personal injury or physical damage.

Depending on circumstances, procedures indicated by ⚠ CAUTION may also be related to serious results.
In any case, it is important to follow the directions for usage.

Associated Manuals

Manual name	Manual No.	Description
FX3U Series User's Manual - Hardware Edition	JY997D16501 MODEL CODE: 09R516	Explains FX3U Series PLC specification details for I/O, wiring, installation, and maintenance.
FX3G/FX3U/FX3UC Series Programming Manual - Basic & Applied Instruction Edition	JY997D16601 MODEL CODE: 09R517	Describes PLC programming for basic/applied instructions and devices.
FX3G/FX3U/FX3UC Series User's Manual - Positioning Control Edition	JY997D16801 MODEL CODE: 09R620	Describes positioning control and programming using FX3G/FX3U/FX3UC Series PLC

How to obtain manuals
For the necessary product manuals or documents, consult with the Mitsubishi Electric dealer from where you purchase your product.

Applicable Standard

FX3U-2HSY-ADP complies with EC directive (EMC Directive) and UL standards (UL, cUL). Further information can be found in the following manual.

→ Refer to FX3U Series Hardware Manual (Manual No. JY997D18801).

Attention

• This product is designed for use in industrial applications.

Note

- Manufactured by: Mitsubishi Electric Corporation
2-7-3 Marunouchi, Chiyoda-ku, Tokyo, 100-8310 Japan

- Manufactured at: Mitsubishi Electric Corporation Himeji Works
840 Chiyoda-machi, Himeji, Hyogo, 670-8677 Japan
- Authorized Representative in the European Community: Mitsubishi Electric Europe B.V.
Gothaer Str. 8, 40880 Ratingen, Germany

1. Outline

The FX3U-2HSY-ADP high-speed output special adapter (hereinafter called high-speed output special adapter) is a special adapter dedicated to FX3U Series PLC. It outputs pulse signals of a differential line driver system for applicable Servo Amplifiers (or Drive Unit) of an AC servomotor or stepper motor.

Up to two units of this special adapter can be connected to the main unit per system.

→ For system configuration, refer to the FX3U Series User's Manual - Hardware Edition.

1.1 Incorporated Items

Check if the following product and items are included in the package:

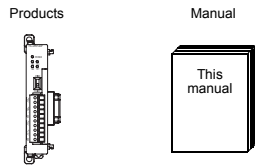

1.2 Output Number and Signal

When power is turned on, the output numbers and signals of the high-speed output special adapters are allocated as shown in the table below in the order of it near the main unit.

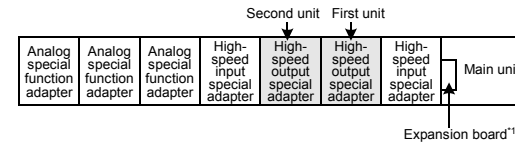

*1 An expansion board is required to use any special adapters other than high-speed I/O special adapters.

→ For system configuration, refer to the FX3U Series User's Manual - Hardware Edition.

Status of output form setting switch	Signal name	Output number			
		First unit		Second unit	
		1st axis	2nd axis	1st axis	2nd axis
FP•RP side	Forward pulse train (FP)	Y000	Y001	Y002	Y003
	Reverse pulse train (RP)	Y004	Y005	Y006	Y007
PLS•DIR side	SG	SGA	SGB	SGA	SGB
	Pulse train	Y000	Y001	Y002	Y003
	Direction	Y004	Y005	Y006	Y007
	SG	SGA	SGB	SGA	SGB

Caution

1) When a high-speed output special adapter is connected, the same output number is allocated to both the main unit and this adapter. Use either output terminal and do not wire to the unused output terminal.
The outputs from the high-speed output special adapter and main unit are operated as below:

instructions	Output operation		
	High-speed output special adapter	Main unit	
		Transistor-output type	Relay-output type/triac-output type
PLSY,PLSR,DSZR, DVIT,TBL,ZRN, PLSV,DRV1,DRVA	Operated	Operated*1	While instruction is activated, relevant output is ON. (LED is also ON.)
PWM	Operated	Operated	Do not use the PWM instruction with relay-output type*2 or triac-output type*3 main units.

instructions	Output operation		
	High-speed output special adapter	Main unit	
		Transistor-output type	Relay-output type/triac-output type
Other	Operated	Operated	Operated

- *1 The output frequency of transistor outputs in the main unit is a maximum of 100kHz. If the load is operated using pulses at a frequency more than 100kHz, PLC may be damaged.
 - *2 PWM instruction has not supported the relay output for the reasons of the response delay of the output, chattering of contact, the contact life, etc.
 - *3 PWM instruction does not support the triac output due to the possibility of response delay of the output.
- 2) During STOP or PLC power off modes, set the output form operation. Do not set the output form operation during pulse train output.

1.3 External Dimensions, Part Names, and Terminal Layout

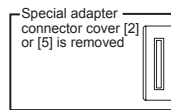
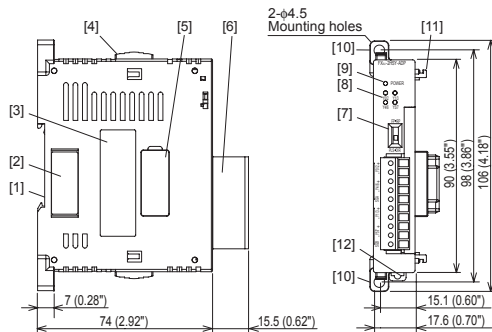

Name	Output number	
	First unit	Second unit
Y0/2	Y000	Y002
Y1/3	Y001	Y003
Y4/6	Y004	Y006
Y5/7	Y005	Y007

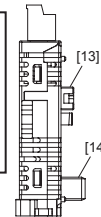

Name	Output number	
	First unit	Second unit
Y0/2+	Y000+	Y002+
Y0/2-	Y000-	Y002-
Y4/6+	Y004+	Y006+
Y4/6-	Y004-	Y006-
SGA	SGA	SGA
Y1/3+	Y001+	Y003+
Y1/3-	Y001-	Y003-
Y5/7+	Y005+	Y007+
Y5/7-	Y005-	Y007-
SGB	SGB	SGB

	[7] Output mode setting switch	
	Name	Setting
Upper	FP•RP side	Fwd pulse train (FP) Rev pulse train (RP)
Lower	PLS•DIR	Pulse train + direction

Unit : mm (inches)
Weight: 80 g (0.18 lbs)

- DIN rail mounting groove (DIN rail: DIN46277)
- High-speed I/O special adapter connector cover: Remove this cover for connecting high-speed I/O special adapter on the left side.
- Name plate
- Special adapter slide lock: Used to connect special adapter on left side of this special adapter.
- Special adapter connector cover: Remove this cover for connecting special adapter on the left side.
- Output terminal block (European type): Connected to Servo Amplifier (or Drive Unit) to which pulse signal of differential line driver system can be input.

- Output form setting switch
Either "Forward pulse train (FP)/Reverse pulse train (RP)" or "pulse train + direction" is selected. For setting, refer to the following manual.
→ Refer to FX3G/FX3U/FX3UC Series User's Manual - Positioning Control Edition.
- Output LED (red):
Lit when output turns ON (if output turns ON and OFF alternately at high speed, LED flickers fast).
- POWER LED (green):
Lit while power is properly supplied from main unit.
- Direct mounting hole: 2 holes of $\phi 4.5$ (0.18") (mounting screw: M4 screw)
- Special adapter fixing hook
- DIN rail mounting hook
- Special adapter connector:
Used to connect communication special adapter or analog special adapter to this adapter on left side.
- High-speed I/O special adapter connector:
Used to connect high-speed I/O special adapter to this adapter on left side.

2. Installation

The product can be mounted on DIN rail (DIN46277) or mounted directly using screws.

For installation/uninstallation and safety precautions, refer to the following manual, too:

→ Refer to the FX3U Series User's Manual - Hardware Edition.

INSTALLATION PRECAUTIONS ⚠ DANGER

- Make sure to cut off all phases of the power supply externally before attempting installation or wiring work. Failure to do so may cause electric shock or damage to the product.

INSTALLATION PRECAUTIONS ⚠ CAUTION

- Use the product within the generic environment specifications described in PLC main unit manual (Hardware Edition). Never use the product in areas with excessive dust, oily smoke, conductive dusts, corrosive gas (salt air, Cl₂, H₂S, SO₂ or NO₂), flammable gas, vibration or impacts, or expose it to high temperature, condensation, or rain and wind.
If the product is used in such conditions, electric shock, fire, malfunctions, deterioration or damage may occur.
- When drilling screw holes or wiring, make sure that cutting and wiring debris do not enter the ventilation slits. Failure to do so may cause fire, equipment failures or malfunctions.
- Do not touch the conductive parts of the product directly. Doing so may cause device failures or malfunctions.
- Connect the special adapter securely to their designated connectors. Loose connections may cause malfunctions.

2.1 Connection to the FX3U Series PLC

- Refer to the procedure 2) for configuring a new system.
- Refer to the procedure 1) for adding product to an existing system.

Procedure

- Turn off the power.
Disconnect all the cables connected to the PLC main unit and special adapter. Dismount the main unit and special adapter mounted on DIN rail or mounted directly using screws.
- Install an expansion board to the main unit.
For installation of expansion board, refer to the following manual:
→ Refer to the FX3U Series User's Manual - Hardware Edition

3) Remove the high-speed I/O special adapter connector cover (Right fig. A) and the special adapter connector cover (Right fig. B) on the main unit.

In case of connecting this product to a high-speed I/O special adapter as an addition, please replace the 'main unit' in the above description with a 'special adapter' and perform the procedure as indicated. (Please replace the following procedures similarly.)

- Slide the special adapter slide lock (Right fig. C) of the main unit.

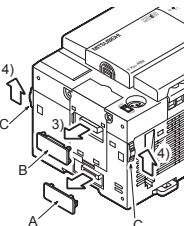

- Connect the high-speed I/O special adapter (Right fig.D) to the main unit as shown on the right.
- Slide back the special adapter slide lock (Right fig.C) of the main unit to fix the high-speed I/O special adapter (Right fig.C).

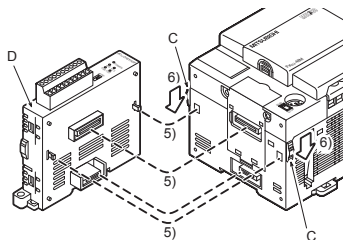

Connection precautions

- Install the expansion board to be used before connecting a special adapter.
- Install an expansion board when using a special adapter other than a high-speed I/O special adapter in combination with a high-speed I/O special adapter.**
- Connect all the high-speed I/O special adapters before connecting other special adapters when they are used in combination.
Do not connect a high-speed I/O special adapter on the left side of any special adapters other than other high-speed I/O special adapters.

3. Used cables and Tightening Torque on Terminal

For connection example and wiring, refer to the following manual.

→ Refer to **FX3G/FX3U/FX3UC Series User's Manual - Positioning Control Edition**.

WIRING PRECAUTIONS	⚠ DANGER
<ul style="list-style-type: none"> Make sure to cut off all phases of the power supply externally before attempting installation or wiring work. Failure to do so may cause electric shock or damage to the product. 	

WIRING PRECAUTIONS	⚠ CAUTION
<ul style="list-style-type: none"> When wiring, make sure cutting or wire debris does not enter the ventilation slits. Failure to do so may cause fire, equipment failures or malfunctions. Make sure to observe the following precautions in order to prevent any damage to the machinery or accidents due to abnormal data written to the PLC under the influence of noise: <ol style="list-style-type: none"> Do not bundle the main circuit line together with or lay it close to the main circuit, high-voltage line or load line. Otherwise, noise disturbance and/or surge induction are likely to take place. As a guideline, lay the control line at least 100mm (3.94") or more away from the main circuit or high-voltage lines. Ground the shield wire or shield of the shielded cable at one point on the PLC. However, do not use common grounding with heavy electrical systems. Make sure to properly wire to the European terminal board in accordance with the following precautions. Failure to do so may cause electric shock, equipment failures, a short-circuit, wire breakage, malfunctions, or damage to the product. <ul style="list-style-type: none"> The disposal size of the cable end should follow the dimensions described in the manual. Tightening torque should follow the specifications in the manual. Twist the end of strand wire and make sure that there are no loose wires. Do not solder-plate the electric wire ends. Do not connect more than the specified number of wires or electric wires of unspecified size. Affix the electric wires so that neither the terminal block nor the connected parts are directly stressed. 	

- Wire size
To connect to the desired unit, use a shielded twisted pair cable having a conductor(s) of size AWG22-20.

2) Applicable cable	
Type	Wire size
Single-wire	0.3mm ² to 0.5mm ² (AWG22 to 20)
2-wire	2 pieces of 0.3mm ² (AWG22)

- Termination of cable end
Strip the coating of strand wire and twist the cable core before connecting it, or strip the coating of single wire before connecting it.
An alternative connection is to use a ferrule with insulating sleeve.

Manufacturer	Model	Caulking tool
Phoenix Contact Co., Ltd.	AI 0.5-8WH	CRIMPFOX 6 ^{*1} (CRIMPFOX 6T-F ^{*2})

*1 Old model name: CRIMPFOX ZA 3

*2 Old model name: CRIMPFOX UD 6

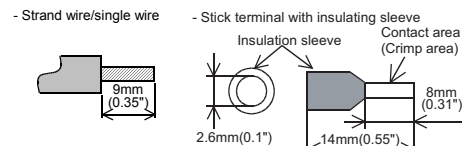

When using a stick terminal with insulating sleeve, choose a wire with proper cable sheath referring to the above outside dimensions, or otherwise, the wire cannot be inserted easily.

The tightening torque must be 0.22 to 0.25N-m.

Do not tighten terminal screws with a torque exceeding the regulation torque. Failure to do so may cause equipment failures or malfunctions.

4. Specification

STARTUP AND MAINTENANCE PRECAUTIONS	⚠ CAUTION
<ul style="list-style-type: none"> Do not disassemble or modify the PLC. Doing so may cause fire, equipment failures, or malfunctions. *For repair, contact your local Mitsubishi Electric distributor. Do not drop the product or exert strong impact to it. Doing so may cause damage. 	

DISPOSAL PRECAUTIONS	⚠ DANGER
<ul style="list-style-type: none"> Please contact a certified electronic waste disposal company for the environmentally safe recycling and disposal of your device. 	

TRANSPORT AND STORAGE PRECAUTIONS	⚠ CAUTION
<ul style="list-style-type: none"> The product is a precision instrument. During transportation, avoid any impacts. Failure to do so may cause failures in the product. After transportation, verify the operations of the product. 	

4.1 Applicable PLC

Model name	Applicability
FX3U Series PLC	Ver. 2.20 (from the first product) and later

The version number can be checked by monitoring D8001 as the last three digits indicate it.

Note

Cannot be connected to FX3G/FX3UC Series PLC.

4.2 General Specifications

For general specifications, refer to the manual of the PLC main unit. The items other than the following are equivalent to those of the PLC main unit.

→ Refer to **FX3U Series User's Manual - Hardware Edition**.

Item	Specification	
Dielectric withstand voltage	500V AC for one minute	Between output terminal of high-speed output special adapter and ground terminal of PLC main unit
Insulation resistance	5MΩ or more by 500V DC megger	

4.3 Power Supply Specification

Item	Specification
Output circuit driving power supply	60mA for 24V DC Internally supplied from the main unit service power supply.
Adapter driving power supply	30mA for 5V DC 5V DC power is supplied internally from the main unit.

4.4 Performance Specification

Item	Specification
Number of controlled axis	Independent two axes
Output points	4 points (Not counted among the total I/O points of the PLC.)
Output system	Differential line driver (Equivalent to AM26C31)
Output form	Forward pulse train, reverse pulse train, or pulse train + direction
Load current	25 mA or less

Item	Specification
Maximum output frequency	200 kHz
Insulation	<ul style="list-style-type: none"> External cables of output area are insulated from PLC by photo coupler or transformer. SG are insulated from each other by transformer.
Wiring length	Maximum 10m (32' 9")

4.5 Output Interface Internal Circuit

For connection example and wiring, refer to the following manual.

→ Refer to **FX3G/FX3U/FX3UC Series User's Manual - Positioning Control Edition**

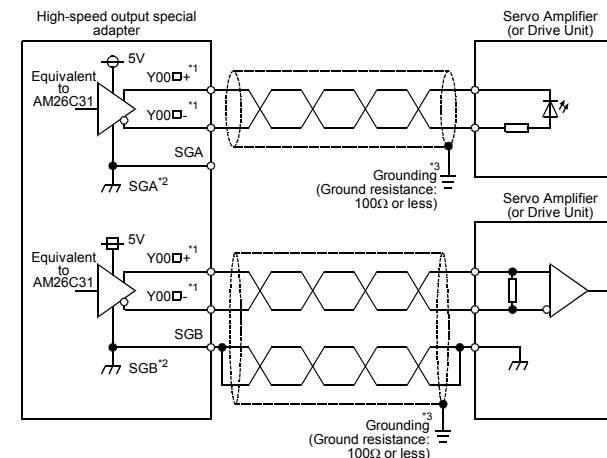

*1 Y00□ indicates output number of the high-speed output special adapter.

*2 'SGA' is insulated from 'SGB'.

*3 Ground properly with reference to the Servo Amplifier (or Drive Unit) manual. If not indicated, ground as below.

Grounding

Ground properly with reference to the Servo Amplifier (or Drive Unit) manual. If not indicated, ground as below.

- Grounding (when not indicated)
- The grounding resistance should be 100Ω or less.
- Independent grounding should be performed for best results.
When independent grounding is not performed, perform "shared grounding" of the following figure.

→ For details, refer to the **FX3U Series User's Manual - Hardware Edition**.

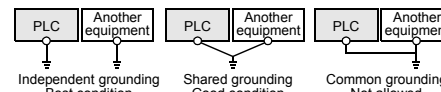

- The grounding wire size should be AWG 14 (2 mm²) or larger.
- The grounding point should be close to the PLC, and all grounding wire should be as short as possible.

This manual confers no industrial property rights or any rights of any other kind, nor does it confer any patent licenses. Mitsubishi Electric Corporation cannot be held responsible for any problems involving industrial property rights which may occur as a result of using the contents noted in this manual.

Warranty

Mitsubishi will not be held liable for damage caused by factors found not to be the cause of Mitsubishi; machine damage or lost profits caused by faults in the Mitsubishi products; damage, secondary damage, accident compensation caused by special factors unpredictable by Mitsubishi; damages to products other than Mitsubishi products; and to other duties.

⚠ For safe use

- This product has been manufactured as a general-purpose part for general industries, and has not been designed or manufactured to be incorporated in a device or system used in purposes related to human life.
- Before using the product for special purposes such as nuclear power, electric power, aerospace, medicine or passenger movement vehicles, consult with Mitsubishi Electric.
- This product has been manufactured under strict quality control. However when installing the product where major accidents or losses could occur if the product fails, install appropriate backup or failsafe functions in the system.

MITSUBISHI ELECTRIC CORPORATION

HEAD OFFICE : TOKYO BUILDING, 2-7-3 MARUNOUCHI, CHIYODA-KU, TOKYO 100-8310, JAPAN

HIMEJI WORKS : 840, CHIYODA CHO, HIMEJI, JAPAN

MITSUBISHI PROGRAMMABLE CONTROLLERS MELSEC-F

Changes for the Better

FX3U-2HSY-ADP

INSTALLATION MANUAL

Manual Number: JY997D16401
Revision: C
Date: September 2010

This manual describes the part names, dimensions, mounting, and specifications of the product. Before use, read this manual and manuals of relevant products fully to acquire proficiency in handling and operating the product. Make sure to learn all the product information, safety information, and precautions. And, store this manual in a safe place so that you can take it out and read it whenever necessary. Always forward it to the end user.

Registration
The company name and the product name to be described in this manual are the registered trademarks or trademarks of each company.

Effective September 2010
Specifications are subject to change without notice.

© 2005 Mitsubishi Electric Corporation

Safety Precaution (Read these precautions before use.)
This manual classify the safety precautions into two categories:
⚠️ DANGER and ⚠️ CAUTION.

DANGER Indicates that incorrect handling may cause hazardous conditions, resulting in death or severe injury.

CAUTION Indicates that incorrect handling may cause hazardous conditions, resulting in medium or slight personal injury or physical damage.

Depending on circumstances, procedures indicated by ⚠️ CAUTION may also be linked to serious results. In any case, it is important to follow the directions for usage.

Associated Manuals

Manual name	Manual No.	Description
FX3U Series User's Manual - Hardware Edition	JY997D16501 MODEL CODE: 09R516	Explains FX3U Series PLC specification details for I/O, wiring, installation, and maintenance.
FX3G/FX3U/FX3UC Series Programming Manual - Basic & Applied Instruction Edition	JY997D16601 MODEL CODE: 09R517	Describes PLC programming for basic/applied instructions and devices.
FX3G/FX3U/FX3UC Series User's Manual - Positioning Control Edition	JY997D16801 MODEL CODE: 09R620	Describes positioning control and programming using FX3G/FX3U/FX3UC Series PLC

How to obtain manuals
For the necessary product manuals or documents, consult with the Mitsubishi Electric dealer from where you purchase your product.

Applicable Standard
FX3U-2HSY-ADP complies with EC directive (EMC Directive) and UL standards (UL, cUL). Further information can be found in the following manual.
→ Refer to FX3U Series Hardware Manual (Manual No. JY997D18801).

Attention
• This product is designed for use in industrial applications.

Note
• Manufactured by:
Mitsubishi Electric Corporation
2-7-3 Marunouchi, Chiyoda-ku, Tokyo, 100-8310 Japan

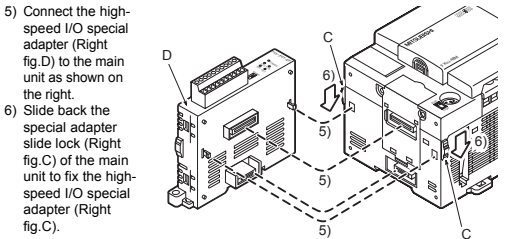

Connection precautions

- Install the expansion board to be used before connecting a special adapter.
- Install an expansion board when using a special adapter other than a high-speed I/O special adapter in combination with a high-speed I/O special adapter.
- Connect all the high-speed I/O special adapters before connecting other special adapters when they are used in combination. Do not connect a high-speed I/O special adapter on the left side of any special adapters other than other high-speed I/O special adapters.

3. Used cables and Tightening Torque on Terminal
For connection example and wiring, refer to the following manual.
→ Refer to FX3G/FX3U/FX3UC Series User's Manual - Positioning Control Edition.

WIRING PRECAUTIONS ⚠️ DANGER

- Make sure to cut off all phases of the power supply externally before attempting installation or wiring work. Failure to do so may cause electric shock or damage to the product.

WIRING PRECAUTIONS ⚠️ CAUTION

- When wiring, make sure cutting or wire debris does not enter the ventilation slits. Failure to do so may cause fire, equipment failures or malfunctions.
- Make sure to observe the following precautions in order to prevent any damage to the machinery or accidents due to abnormal data written to the PLC under the influence of noise:
 - Do not bundle the main circuit line together with or lay it close to the main circuit, high-voltage line or load line. Otherwise, noise disturbance and/or surge induction are likely to take place. As a guideline, lay the control line at least 100mm (3.94") or more away from the main circuit or high-voltage lines.
 - Ground the shield wire or shield of the shielded cable at one point on the PLC. However, do not use common grounding with heavy electrical systems.
- Make sure to properly wire to the European terminal board in accordance with the following precautions. Failure to do so may cause electric shock, equipment failures, a short-circuit, wire breakage, malfunctions, or damage to the product.
 - The disposal size of the cable end should follow the dimensions described in the manual.
 - Tightening torque should follow the specifications in the manual.
 - Twist the end of strand wire and make sure that there are no loose wires.
 - Do not solder-plate the electric wire ends.
 - Do not connect more than the specified number of wires or electric wires of unspecified size.
 - Affix the electric wires so that neither the terminal block nor the connected parts are directly stressed.

1) Wire size
To connect to the desired unit, use a shielded twisted pair cable having a conductor(s) of size AWG22-20.

2) Applicable cable

Type	Wire size
Single-wire	0.3mm ² to 0.5mm ² (AWG22 to 20)
2-wire	2 pieces of 0.3mm ² (AWG22)

3) Termination of cable end
Strip the coating of strand wire and twist the cable core before connecting it, or strip the coating of single wire before connecting it. An alternative connection is to use a ferrule with insulating sleeve.

Manufacturer	Model	CaULKing tool
Phoenix Contact Co., Ltd.	AI 0.5-8WH	CRIMPFOX 6 ⁻¹ (CRIMPFOX 6T-F ⁻²)

*1 Old model name: CRIMPFOX ZA 3
*2 Old model name: CRIMPFOX UD 6

- Manufactured at:
Mitsubishi Electric Corporation Himeji Works
840 Chiyoda-machi, Himeji, Hyogo, 670-8677 Japan
- Authorized Representative in the European Community:
Mitsubishi Electric Europe B.V.
Gothaer Str. 8, 40880 Ratingen, Germany

1. Outline
The FX3U-2HSY-ADP high-speed output special adapter (hereinafter called high-speed output special adapter) is a special adapter dedicated to FX3U Series PLC. It outputs pulse signals of a differential line driver system for applicable Servo Amplifiers (or Drive Unit) of an AC servomotor or stepper motor. Up to two units of this special adapter can be connected to the main unit per system.
→ For system configuration, refer to the FX3U Series User's Manual - Hardware Edition.

1.1 Incorporated Items
Check if the following product and items are included in the package:

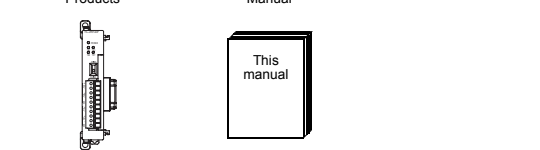

1.2 Output Number and Signal
When power is turned on, the output numbers and signals of the high-speed output special adapters are allocated as shown in the table below in the order of it near the main unit.

Analog special function adapter	Analog special function adapter	Analog special function adapter	High-speed input special adapter	High-speed output special adapter	High-speed output special adapter	High-speed output special adapter	High-speed output special adapter	Main unit

*1 An expansion board is required to use any special adapters other than high-speed I/O special adapters.
→ For system configuration, refer to the FX3U Series User's Manual - Hardware Edition.

Status of output form setting switch	Signal name	Output number			
		First unit		Second unit	
		1st axis	2nd axis	1st axis	2nd axis
FP+RP side	Forward pulse train (FP)	Y000	Y001	Y002	Y003
	Reverse pulse train (RP)	Y004	Y005	Y006	Y007
PLS+DIR side	SG	SGA	SGB	SGA	SGB
	Pulse train	Y000	Y001	Y002	Y003
	Direction	Y004	Y005	Y006	Y007
	SG	SGA	SGB	SGA	SGB

Caution
1) When a high-speed output special adapter is connected, the same output number is allocated to both the main unit and this adapter. Use either output terminal and do not wire to the unused output terminal.
The outputs from the high-speed output special adapter and main unit are operated as below.

instructions	Output operation		
	High-speed output special adapter	Main unit	
		Transistor-output type	Relay-output type/ triac-output type
PLSY,PLSR,DSZR, DVIT,TBL,ZRN, PLSV,DRV1,DRVA	Operated	Operated*1	While instruction is activated, relevant output is ON. (LED is also ON.)
PWM	Operated	Operated	Do not use the PWM instruction with relay-output type*2 or triac-output type*3 main units.

4. Specification

STARTUP AND MAINTENANCE PRECAUTIONS ⚠️ CAUTION

- Do not disassemble or modify the PLC. Doing so may cause fire, equipment failures, or malfunctions. *For repair, contact your local Mitsubishi Electric distributor.
- Do not drop the product or exert strong impact to it. Doing so may cause damage.

DISPOSAL PRECAUTIONS ⚠️ DANGER

- Please contact a certified electronic waste disposal company for the environmentally safe recycling and disposal of your device.

TRANSPORT AND STORAGE PRECAUTIONS ⚠️ CAUTION

- The product is a precision instrument. During transportation, avoid any impacts. Failure to do so may cause failures in the product. After transportation, verify the operations of the product.

4.1 Applicable PLC

Model name	Applicability
FX3U Series PLC	Ver. 2.20 (from the first product) and later

The version number can be checked by monitoring D8001 as the last three digits indicate it.
Note
Cannot be connected to FX3G/FX3UC Series PLC.

4.2 General Specifications
For general specifications, refer to the manual of the PLC main unit. The items other than the following are equivalent to those of the PLC main unit.
→ Refer to FX3U Series User's Manual - Hardware Edition.

Item	Specification
Dielectric withstand voltage	500V AC for one minute
Insulation resistance	5MΩ or more by 500V DC megger

4.3 Power Supply Specification

Item	Specification
Output circuit driving power supply	60mA for 24V DC internally supplied from the main unit service power supply.
Adapter driving power supply	30mA for 5V DC 5V DC power is supplied internally from the main unit.

4.4 Performance Specification

Item	Specification
Number of controlled axis	Independent two axes
Output points	4 points (Not counted among the total I/O points of the PLC.)
Output system	Differential line driver (Equivalent to AM26C31)
Output form	Forward pulse train, reverse pulse train, or pulse train + direction
Load current	25 mA or less

instructions	Output operation		
	High-speed output special adapter	Main unit	
		Transistor-output type	Relay-output type/ triac-output type
Other	Operated	Operated	Operated

- The output frequency of transistor outputs in the main unit is a maximum of 100kHz. If the load is operated using pulses at a frequency more than 100kHz, PLC may be damaged.
- PWM instruction has not supported the relay output for the reasons of the response delay of the output, chattering of contact, the contact life, etc.
- PWM instruction does not support the triac output due to the possibility of response delay of the output.

2) During STOP or PLC power off modes, set the output form operation. Do not set the output form operation during pulse train output.

1.3 External Dimensions, Part Names, and Terminal Layout

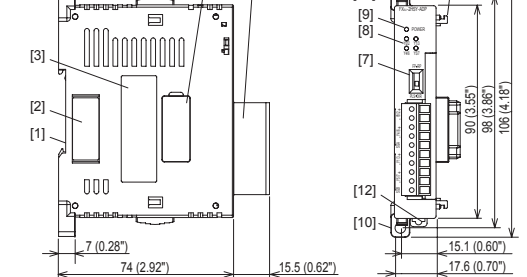

Special adapter connector cover [2] or [5] is removed

Name	Output number	
	First unit	Second unit
Y0/2	Y000+	Y002+
Y1/3	Y001	Y003
Y4/6	Y004	Y006
Y5/7	Y005	Y007
SGB	SGB	SGB

Terminal layout of [6]

Name	Output number	
	First unit	Second unit
Y0/2+	Y000+	Y002+
Y0/2-	Y000-	Y002-
Y4/6+	Y004+	Y006+
Y4/6-	Y004-	Y006-
SGA	SGA	SGA
Y1/3+	Y001+	Y003+
Y1/3-	Y001-	Y003-
Y5/7+	Y005+	Y007+
Y5/7-	Y005-	Y007-
SGB	SGB	SGB

[7] Output mode setting switch

	Name	Setting
Upper	FP+RP side	Fwd pulse train (FP) Rev pulse train (RP)
Lower	PLS+DIR	Pulse train + direction

Unit : mm (inches)
Weight: 80 g (0.18 lbs)

- DIN rail mounting groove (DIN rail: DIN46277)
- High-speed I/O special adapter connector cover: Remove this cover for connecting high-speed I/O special adapter on the left side.
- Name plate
- Special adapter slide lock: Used to connect special adapter on left side of this special adapter.
- Special adapter connector cover: Remove this cover for connecting special adapter on the left side.
- Output terminal block (European type): Connected to Servo Amplifier (or Drive Unit) to which pulse signal of differential line driver system can be input.

Item	Specification
Maximum output frequency	200 kHz
Insulation	External cables of output area are insulated from PLC by photo coupler or transformer. SG are insulated from each other by transformer.
Wiring length	Maximum 10m (32' 9")

4.5 Output Interface Internal Circuit
For connection example and wiring, refer to the following manual.
→ Refer to FX3G/FX3U/FX3UC Series User's Manual - Positioning Control Edition

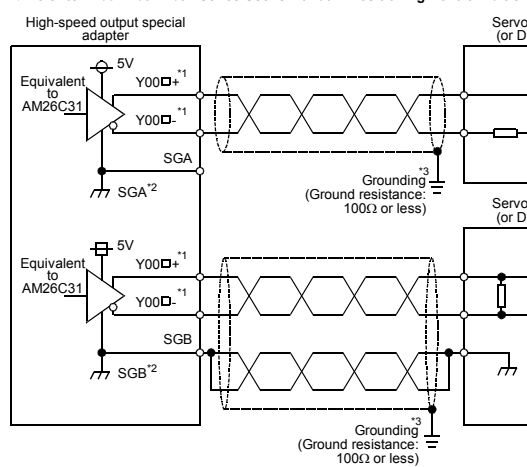

*1 Y00□ indicates output number of the high-speed output special adapter.
*2 "SGA" is insulated from "SGB".
*3 Ground properly with reference to the Servo Amplifier (or Drive Unit) manual. If not indicated, ground as below.

Grounding
Ground properly with reference to the Servo Amplifier (or Drive Unit) manual. If not indicated, ground as below.

- Grounding (when not indicated)
- The grounding resistance should be 100Ω or less.
- Independent grounding should be performed for best results. When independent grounding is not performed, perform "shared grounding" of the following figure.

→ For details, refer to the FX3U Series User's Manual - Hardware Edition.

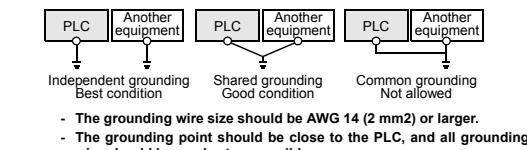

- The grounding wire size should be AWG 14 (2 mm²) or larger.
- The grounding point should be close to the PLC, and all grounding wire should be as short as possible.

- Output form setting switch
Either "Forward pulse train (FP)/Reverse pulse train (RP)" or "pulse train + direction" is selected. For setting, refer to the following manual.
→ Refer to FX3G/FX3U/FX3UC Series User's Manual - Positioning Control Edition.
- Output LED (red):
Lit when output turns ON (if output turns ON and OFF alternately at high speed, LED flickers fast).
- POWER LED (green):
Lit while power is properly supplied from main unit.
- Direct mounting hole: 2 holes of φ4.5 (0.18") (mounting screw: M4 screw)
- Special adapter fixing hook
- DIN rail mounting hook
- Special adapter connector:
Used to connect communication special adapter or analog special adapter to this adapter on left side.
- High-speed I/O special adapter connector:
Used to connect high-speed I/O special adapter to this adapter on left side.

2. Installation
The product can be mounted on DIN rail (DIN46277) or mounted directly using screws.
For installation/uninstallation and safety precautions, refer to the following manual, too.
→ Refer to the FX3U Series User's Manual - Hardware Edition.

INSTALLATION PRECAUTIONS ⚠️ DANGER

- Make sure to cut off all phases of the power supply externally before attempting installation or wiring work. Failure to do so may cause electric shock or damage to the product.

INSTALLATION PRECAUTIONS ⚠️ CAUTION

- Use the product within the generic environment specifications described in PLC main unit manual (Hardware Edition). Never use the product in areas with excessive dust, oily smoke, conductive dusts, corrosive gas (salt air, Cl₂, H₂S, SO₂ or NO₂), flammable gas, vibration or impacts, or expose it to high temperature, condensation, or rain and wind. If the product is used in such conditions, electric shock, fire, malfunctions, deterioration or damage may occur.
- When drilling screw holes or wiring, make sure that cutting and wiring debris do not enter the ventilation slits. Failure to do so may cause fire, equipment failures or malfunctions.
- Do not touch the conductive parts of the product directly. Doing so may cause device failures or malfunctions.
- Connect the special adapter securely to their designated connectors. Loose connections may cause malfunctions.

2.1 Connection to the FX3U Series PLC
• Refer to the procedure 2) for configuring a new system.
• Refer to the procedure 1) for adding product to an existing system.

- Procedure**
- Turn off the power.
Disconnect all the cables connected to the PLC main unit and special adapter. Dismount the main unit and special adapter mounted on DIN rail or mounted directly using screws.
 - Install an expansion board to the main unit.
For installation of expansion board, refer to the following manual:
→ Refer to the FX3U Series User's Manual - Hardware Edition
 - Remove the high-speed I/O special adapter connector cover (Right fig. A) and the special adapter connector cover (Right fig. B) on the main unit.
In case of connecting this product to a high-speed I/O special adapter as an addition, please replace the 'main unit' in the above description with a 'special adapter' and perform the procedure as indicated. (Please replace the following procedures similarly.)
 - Slide the special adapter slide lock (Right fig. C) of the main unit.



This manual confers no industrial property rights or any rights of any other kind, nor does it confer any patent licenses. Mitsubishi Electric Corporation cannot be held responsible for any problems involving industrial property rights which may occur as a result of using the contents noted in this manual.

Warranty
Mitsubishi will not be held liable for damage caused by factors found not to be the cause of Mitsubishi; machine damage or lost profits caused by faults in the Mitsubishi products; damage, secondary damage, accident compensation caused by special factors unpredictable by Mitsubishi; damages to products other than Mitsubishi products; and to other duties.

For safe use

- This product has been manufactured as a general-purpose part for general industries, and has not been designed or manufactured to be incorporated in a device or system used in purposes related to human life.
- Before using the product for special purposes such as nuclear power, electric power, aerospace, medicine or passenger movement vehicles, consult with Mitsubishi Electric.
- This product has been manufactured under strict quality control. However when installing the product where major accidents or losses could occur if the product fails, install appropriate backup or failsafe functions in the system.